

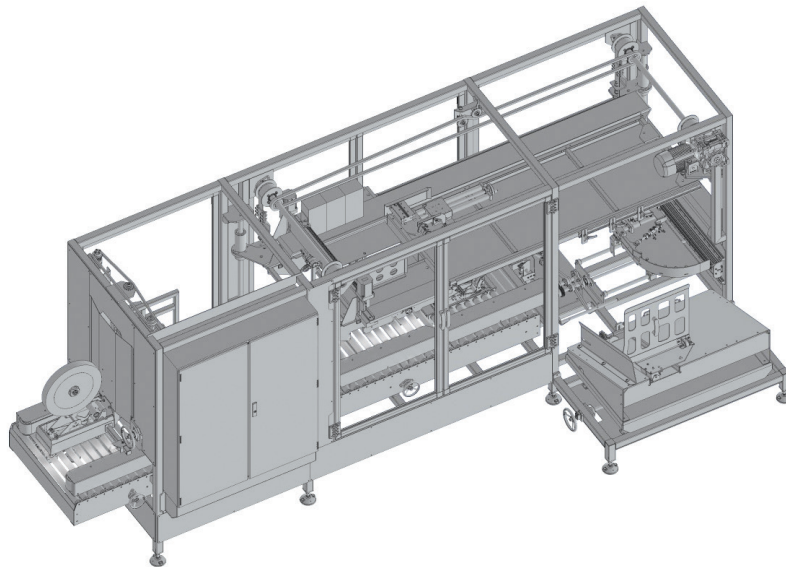

CARTONMAT TL544T

The “3 in 1” Compact Monoblock Case Packer



CartonMat TL544T
is Ideal For



Type “Top Loading”

CartonMat TL544T is a monoblock case packer that receives products directly from the production line, groups them according to a predefined pattern and top loads them into cartons.

It is a “3 in 1” product (carton erecting, packing and sealing) ensuring fully automatic operation and minimum footprint.

With the use of servo, **CartonMat TL544T** ensures high speed and precise product handling while its design makes it ideal for production areas with limited available space.

CartonMat TL544T is IoT ready and incorporates the latest technologies of Industry 4.0.

Benefits

Reliability / Safety / Minimum Maintenance

CartonMat TL544T incorporates our 30 years of engineering excellence and combines intelligent design, top quality materials and robust construction, providing high productivity and minimum downtime and maintenance requirements.

Flexibility / Productivity Assurance / Minimized Operational Cost

CartonMat TL544T is designed to handle various predefined products with quick changeovers. It secures maximum productivity and the reduction of operational costs.

Upgradability

CartonMat TL544T can easily be upgraded to cover new requirements, such as new products and patterns, checkweighing, QC, etc.



CARTONMAT TL544T

The "3 in 1" Compact Monoblock Case Packer

Technical Specifications

PERFORMANCE

Productivity	max 12 cycles per minute
Operation	Fully automatic, Cycle, Manual
Changeovers	max 10 min
Handled products	Pet bottles, Cartons, Cans, Flat Bottom Bags, Pillow Bags
Carton hopper capacity	500 mm

CASES TYPES & DIMENSIONS

Minimum Case Size (LxWxH)	250 x 200 x 100 mm
Maximum Case Size (LxWxH)	500 x 400 x 400 mm
Case Type	RSC

MACHINE DESIGN

Overall Dimensions (LxWxH)	4,600 x 1,800 x 2,000 mm
Infeed Conveyor	Chain or Modular Conveyor Belt, Height (1200 ± 30 mm)
Outfeed Conveyor	Chain or Roller Conveyor, Height (650 ± 30 mm)

CONTROL

PLC	Siemens S7-300
HMI	Siemens KTP-700
Servo & Pneumatics	FESTO

SAFETY

Safety System	Double Emergency Stop circuit, Door Interlocks, CE Certification
---------------	--

SUPPLY REQUIREMENTS

Power Supply	3 x 32A / 400V - 50 Hz (3P + N + GND)
Air Supply	6 Bar

WARRANTY

Full Coverage Warranty	1 Year - Unlimited Cycles
------------------------	---------------------------

Optional Features

Carton Hopper	Extended Motorized hopper
Remote Maintenance	Teleservice
Execution Material	Stainless steel frame or components
Sealing Method	Nordson Hot melt glue for case sealing instead of adhesive tape

DISTRIBUTED BY:



Zenon Automation SAICT
 17, Agiou Athanassiou Str., 19002, Peania, Attica, Greece
 Tel: +30 210 6690900, Fax: +30 210 6640200
 marketing@zenon.gr | www.zenon-robotics.com